

版本 Rev.	日期 Date	变更文件号 ECN NO.	变更内容 Revisions	设计 By
V1.0	20.02.14		初版	王洪松

Dimension: (Unit: mm)

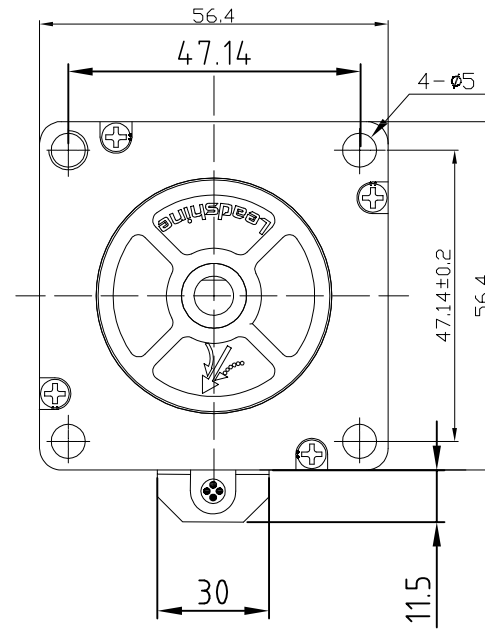

Motor Connctions:

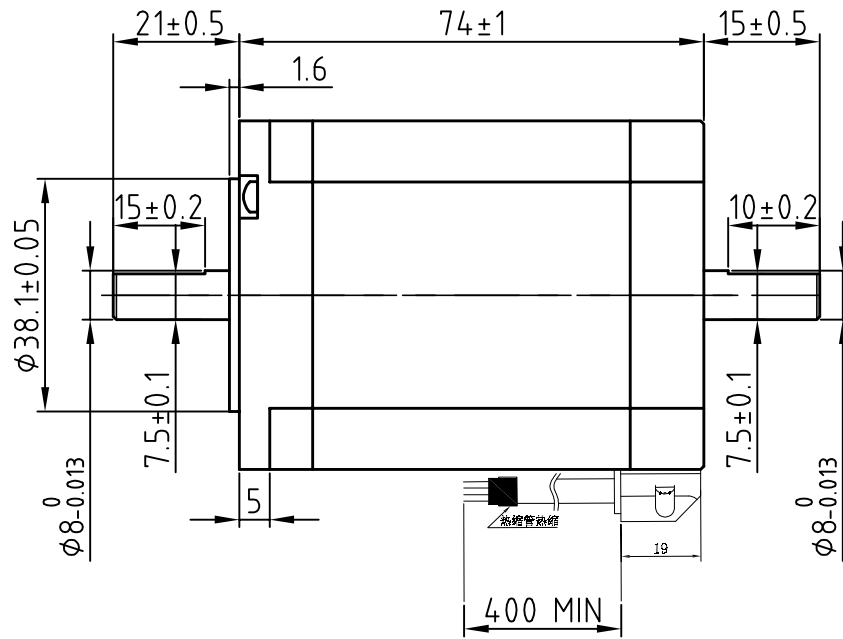
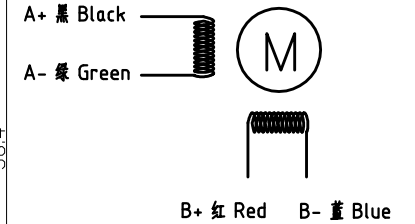

Common Rating

Step angle	1.8°
Position accuracy	1.8±0.9°
Dielectric strength	500VAC 1min
Insulation resistance	100MΩhm(500VDC)
Insulation class	B
Temp rise(Max)	80K
Radial play	Max.0.02mm(Load 450g)
Axial play	Max.0.08mm(Load 900g)

Specification:

Current/phase	5.0 A
Voltage	1.9 V
DC Resistance/phase ±10%	0.38 Ω
Inductance/phase ±20%	1.6 mH
Holding torque	2.2 N·M
Detent torque	0.068 N·M
Inertia	0.480 kg·cm <sup>2</sup>
Weight	1.1 kg

设计 Designed	王洪松	日期 Date	2020.02.14	材料 Material		深圳市雷赛智能控制股份有限公司 SHENZHEN LEADSHINE TECHNOLOGY CO., LTD.
审核 Checked	黄捷建	2020.02.14	第一角画法 First Angle projection		名称 Title	
批准 Approved	黄捷建	2020.02.14	版本/版次 A/01	比例 Scale	阶段标记 Stage Mark	57CM22C-SZ
零件编号 Part No.	LS-MT-01-07A		共 1 页 第 1 页	Sheet 1 of 1	图号 DWG. NO.	LS-57CM22C-SZ