

版本 Rev.	日期 Date	变更文件号 ECN NO.	变更内容 Revisions	设计 By
V1.0	17.10.20		双出轴	王洪松

Dimension: (Unit: mm)

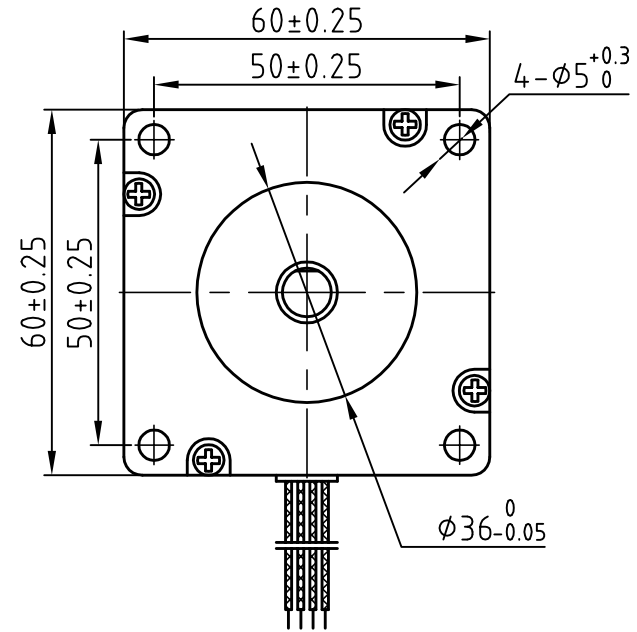
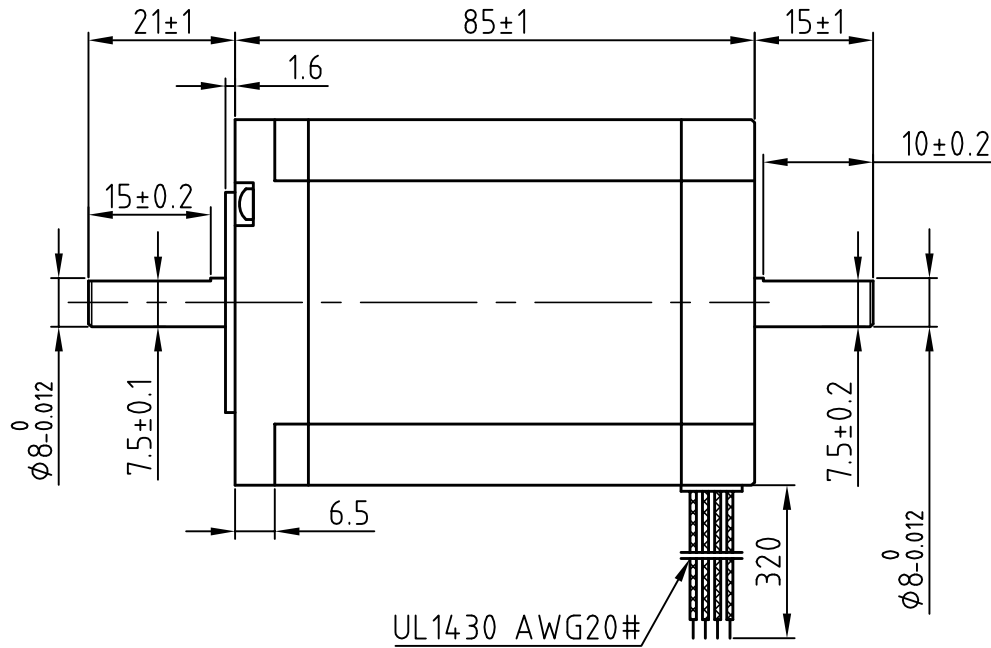

Common Rating

Step angle	1.8°
Position accuracy	1.8±0.09°
Dielectric strength	500VAC 1min
Insulation resistance	100MΩhm(500VDC)
Insulation class	B
Temp rise(Max)	80K
Radial play	Max.0.02mm(Load 450g)
Axial play	Max.0.08mm(Load 900g)

Specification:

Current/phase	5.0 A
Voltage	3.3 V
DC Resistance/phase ±10%	0.46Ω
Inductance/phase ±20%	2.0 mH
Holding torque	3.0 N·M
Inertia	0.69 kg·cm ²
Weight	1.3 kg

Motor Connetions:

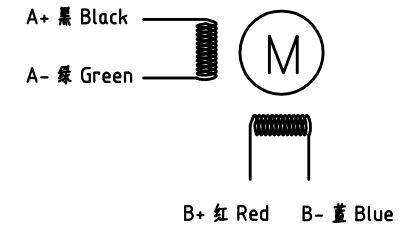

设计 Designed	王洪松	日期 Date	2021.04.21	材料 Material		深圳市雷赛智能控制股份有限公司 SHENZHEN LEADSHINE TECHNOLOGY CO., LTD.	
审核 Checked	黄捷建		2021.04.21	第一角画法 First Angle projection		名称 Title	混合式步进电机
批准 Approved	黄捷建		2021.04.21	版本/版次 A/01	比例 Scale	阶段标记 Stage Mark	60CM30X-SZ
料号 Part No.	LS-MT-01-07A			共 1 页 第 1 页	Sheet 1 of 1	图号 DWG. NO.	LS-60CM30X-SZ