

573SI5-L(REV.B) 3-PHASE HYBRID STEPPING MOTOR

specifications:

MODEL	PHASE	STEP ANGLE	RATED VOLTAGE	LINE CURRENT	RESISTANCE /PHASE	INDUCTANCE /PHASE	HOLDING TORQUE	DETENT TORQUE	ROTOR INERTIA	WEIGHT
		DEG/STEP	V	A	ohms	mH	N.m	N.cm	g.cm ²	Kg
	3	1.2	4.47	5.2	0.86	2	1.5	6.8Max	480	1.1

Wiring Diagram:

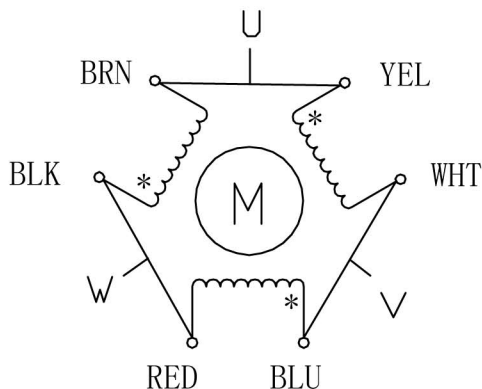

UL1332 AWG22# LENGTH: 400mm

Dimension:

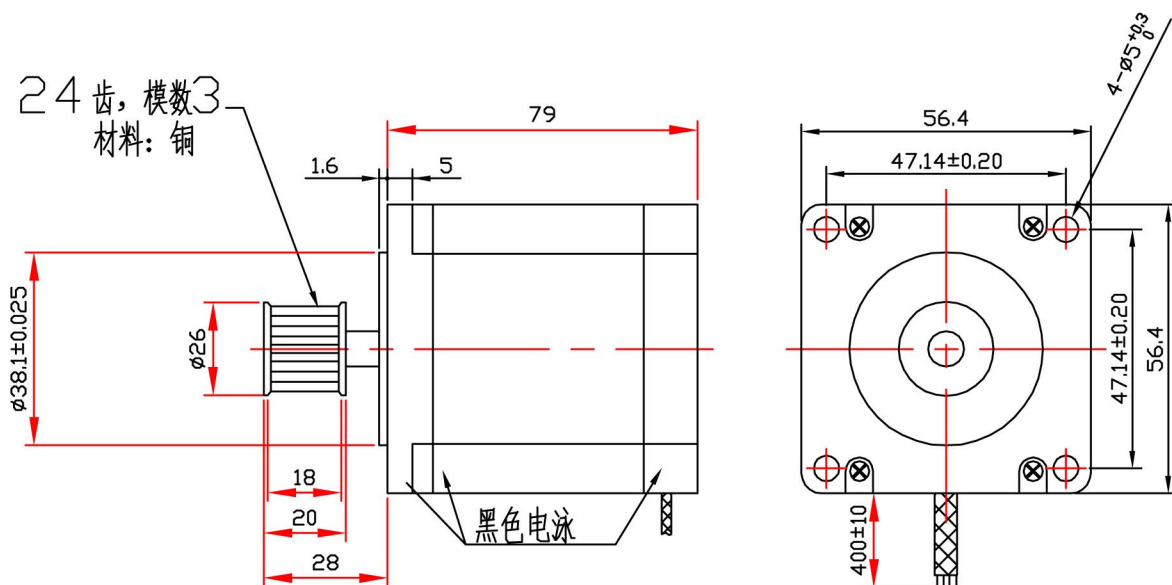

B	080416L2	出轴扁丝取消	LN	JOHN	2008.04.16			
A	080311L2	表面处理改为黑色电泳	LN	JOHN	2008.03.11	DRAWN	DATE	TITLE
REV	ECN	DESCRIPTION	DRN	APP'D	DATE	SPECIFICATIONS		
UNLESS OTHERWISE SPECIFIED MATERIAL TOLERANCES:			CHECK		USED ON			
DECIMALS:		ANGULAR:	APPD		SCALE		DWG NO.	
.x ±0.5		±0°30'					REV	
.xx ±0.25							B	
.xxx ±0.1			THIRD ANGLE PROJECTION		SHEET		OF	
DO NOT SCALE DRAWING						深圳市雷赛智能控制股份有限公司		