

版本 Rev.	日期 Date	变更文件号 ECN NO.	变更内容 Revisions	设计 By
V1.0	17.8.1		带LOGO	王洪松

Dimension: (Unit: mm)

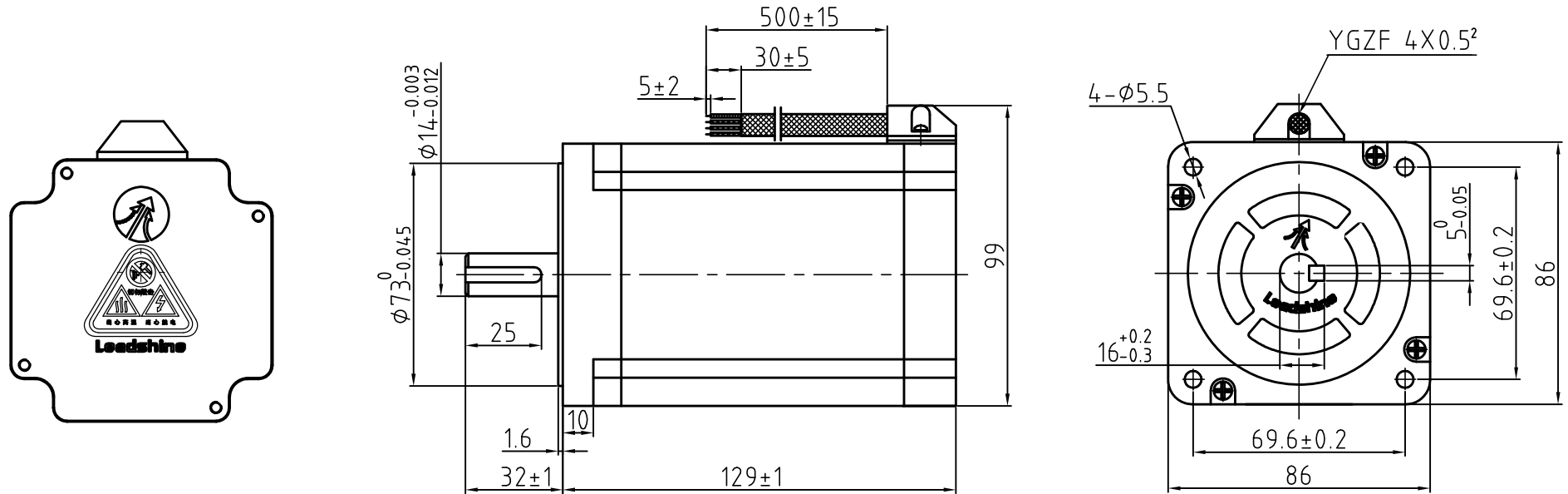

### Common Rating

Step angle	1.8°
Position accuracy	1.8±0.09°
Dielectric strength	1000VAC 1min
Insulation resistance	100MOhm(500VDC)
Insulation class	B
Temp rise(Max)	80K
Radial play	Max.0.02mm(Load 450g)
Axial play	Max.0.08mm(Load 900g)

### Specification

Current/phase	6.0 A
Voltage	4.5 V
DC Resistance/phase ±10%	0.75 Ω
Inductance/phase ±20%	5 mH
Holding torque	12 N·M
Inertia	2.94 kg·cm²
Weight	4.45 kg

### Motor Connctions

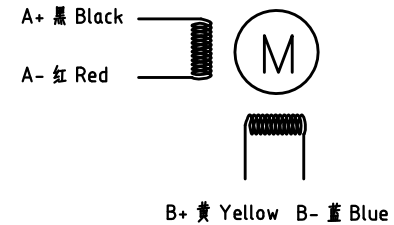

设计 Designed	王洪松	日期 Date	17.8.1	材料 Material	深圳市雷赛智能控制股份有限公司 SHENZHEN LEADSHINE TECHNOLOGY CO., LTD.
审核 Checked	刘佩峰	17.8.1	第一角画法 First Angle projection	名称 Title	混合式步进马达
批准 Approved	田天胜	17.8.1	重量 Weight 比例 Scale 阶段标记 Stage Mark	86CM120	
料号 Part No.				共 1 张 第 1 张 Sheet 1 of 1	图号 DWG. NO.