

版本 Rev.	日期 Date	变更文件号 ECN NO.	变更内容 Revisions	设计 By
V1.0	17.05.18		带LOGO, 新外观	王洪松
	17.09.13			Max

Dimension: (Unit: mm)

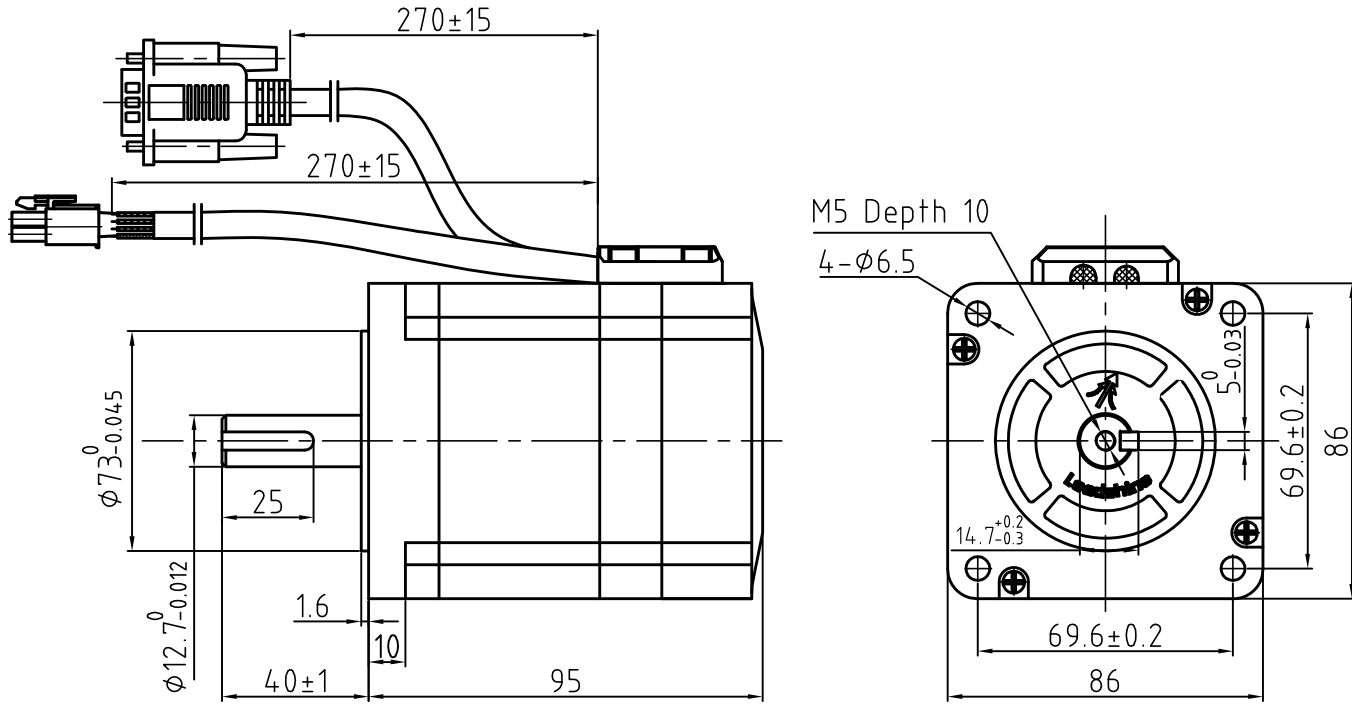

Motor Connctions

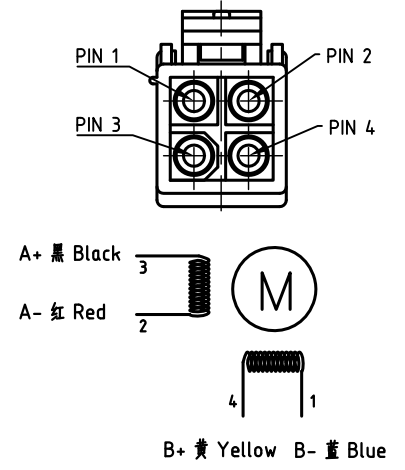

Encoder Signals

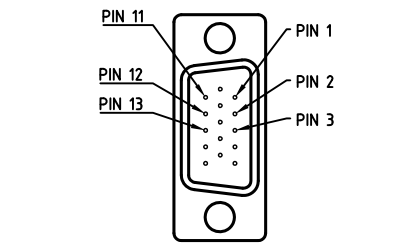

PIN	1	2	3	11	12	13
Color	BLK	RED	WHT	YEL	GRN	BLU
Define	A+	VCC	GND	B+	B-	A-

Common Rating

Step angle	1.8°
Position accuracy	1.8±0.09°
Dielectric strength	1000VAC 1min
Insulation resistance	100M0hm(500VDC)
Insulation class	B
Temp rise(Max)	80K
Radial play	Max.0.02mm(Load 450g)
Axial play	Max.0.08mm(Load 900g)

Specification

Current/phase	4.0 A
Voltage	1.7 V
DC Resistance/phase ±10%	0.42 Ω
Inductance/phase ±20%	2.67 mH
Holding torque	3.5 N·M
Inertia	1 kg·cm <sup>2</sup>
Weight	2.0 kg
Encoder Resolution	1000 ppr (4000 cpr)

设计 Designed	王洪松	日期 Date	2017.05.18	材料 Material	深圳市雷赛智能控制股份有限公司 SHENZHEN LEADSHINE TECHNOLOGY CO., LTD.		
审核 Checked	秦军	2017.05.18		第一角画法 First Angle projection		名称 Title	Closed-loop Stepper Motor
批准 Approved	田天胜	2017.05.18		重量 Weight	比例 Scale	阶段标记 Stage Mark	CS-M23435-S
料号 Part No.				共 1 页 第 1 页 Sheet 1 of 1	图号 DWG. NO.	LS-CM86-01-0010-01	