

DMA882S-IO 2-phase Speed Control Stepper Drive

30-110VDC or 20-80VAC, 2.1-8.2A peak current, Auto-configuration, Low Noise

Features

- External I/O signal control mode, with 5-24 VDC
- DIP switch setting drive's output current and motor speed
- PUL+ and PUL- signals indicate Start and Stop
- DIR+ and DIR- signals indicate motor running direction
- Alarm output (30V/100mA max)
- Matched with NEMA 23, 24, 34, 42 stepper motors
- Suitable for long-term constant speed applications

Power Supply Connection

- Rang 30-110VDC or 20-80VAC, recommend 36-90VDC power supply, higher power voltage brings better performance at high speed.
- No polarity of power

DMA882S-IO Size (unit: mm)

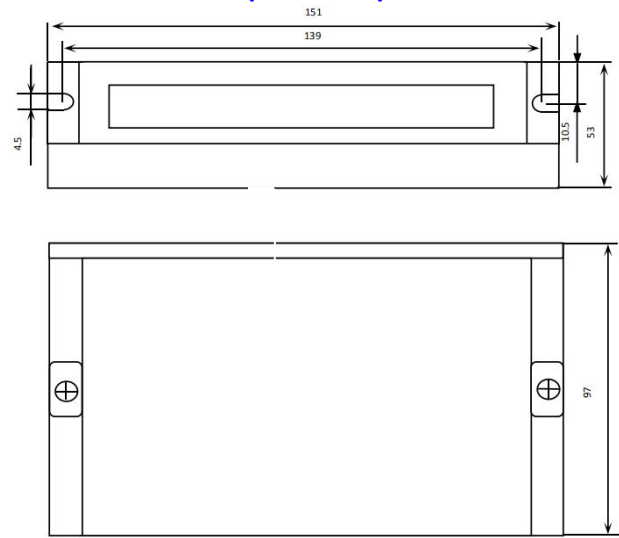

I/O Signals Connection

- The I/O signals connections are as below, PUL signals indicate Start/Stop function, DIR signals indicate motor running direction, SPD signals indicate low speed or high speed.
- if SPD+ & SPD- are no connected, motor speed is setting by SW5-SW8 (also named **high speed**), if SPD+ & SPD- are on, motor speed switch to **low speed** (the value is half of high speed as default, also can be set by Leadshine software). Speed switching takes effect in real time and does not require a power restart.
- Control signals voltage is 5-24VDC.

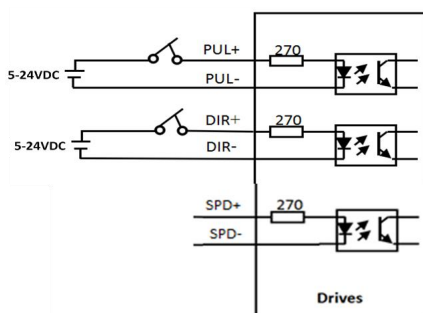

Start motion & CW direction

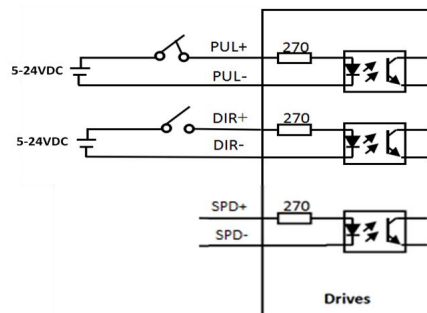

Start motion & CCW direction

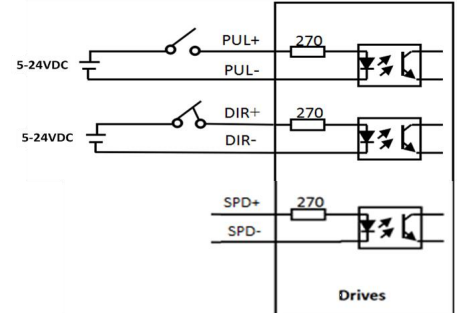

Stop motion

Motor Connection

- DMA882S-IO can match with Leadshine 2-phase stepper motor, size include NEMA23, 24, 34, 42
- The motor connections are shown as below

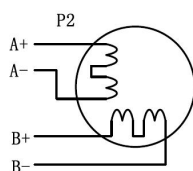

4-lead Motor Connections

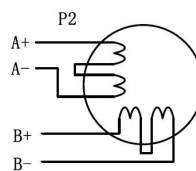

8-lead motor series connections

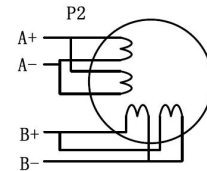

8-lead motor parallel connections

DIP Switch Setting

- DMA882S-IO has 8-bit DIP switches, functions as below:

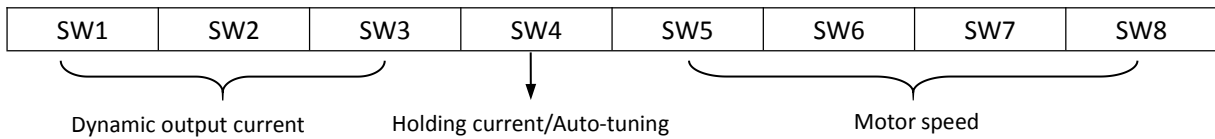

- Output current setting (3-bit)

Peak	RMS	SW1	SW2	SW3
Default(2.1A)		on	on	on
2.7A	1.93A	off	on	on
3.6A	2.57A	on	off	on
4.6A	3.29A	off	off	on
5.5A	3.93A	on	on	off
6.4A	4.57A	off	on	off
7.3A	5.21A	on	off	off
8.2A	5.86A	off	off	off

- Holding current(SW4)

“Off” means holding current is 60% of dynamic current, while “on” means 100%.

Auto-configuration for current loop at power on

Note:

- (1) Factory is turned on auto-tuning, need to use PC software to turn off.
- (2) “Default” means that parameters can be modified by Leadshine software.

- Motor speed setting (4-bit)

Motor Speed (RPM)	SW5	SW6	SW7	SW8
Default (50)	on	on	on	on
150	off	on	on	on
250	on	off	on	on
350	off	off	on	on
450	on	on	off	on
550	off	on	off	on
650	on	off	off	on
750	off	off	off	on
850	on	on	on	off
950	off	on	on	off
40	on	off	on	off
60	off	off	on	off
70	on	on	off	off
80	off	on	off	off
90	on	off	off	off
100	off	off	off	off



Be sure to read this manual carefully before trying to install and use the product.

Be sure to check the connections and make sure the power lead polarity is correct, or there could result in injury or fire.

Be sure to ground the earth terminal of the motor and drive without fail, or there could result in electrical shock.

Be sure to mount the load after making sure the motor work well without load, or there could result in some accident.

Be sure to turn off power and wait for 10 minutes or longer after LED display of the front panel has gone off, and then you can transporting, wiring and inspecting the drive, or there could result in electrical shock or fire.

Be sure to install an emergency stop circuit externally so that you can stop the operation and shut off the power immediately, or there could result in some accident.

Be sure to give the power supply voltage does not exceed the drive's input range, or there could result in burning out drive and motor.