

# M415B Micro Microstepping Driver

## 1. Introduction

The M415B is a very small size high performance microstepping driver based on one of the most advanced technologies in the world today. It's suitable for driving any 2-phase and 4-phase hybrid stepping motors. By using advanced bipolar constant-current chopping technique, it can output more speed and power from the same motor, compared with traditional drivers such as L/R drivers.

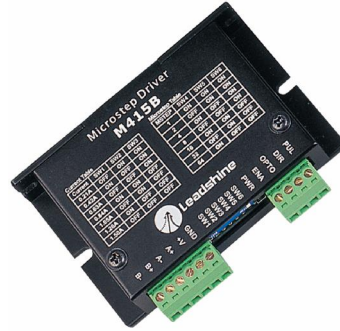

## 2. Features

- High performance, low cost
- Supply voltage up to +40VDC
- Output current up to 1.5A
- Inaudible 20 KHz chopping frequency
- TTL compatible and optically isolated input signals
- Automatic idle-current reduction
- Mixed-decay current control for less motor heating
- 7 selectable microstep resolutions: 1, 2, 4, 8, 16, 32, 64
- Suitable for 2-phase and 4-phase motors
- Protection against power leads(+, -)reversal
- Small size: 86\*55\*20mm

## 3. Applications

Suitable for a wide range of stepping motors from NEMA size 16 to 23, which used in various kinds of machines, such as X-Y tables, labeling machines, laser cutters, engraving machines, pick-place devices, and etc. It's specially adapted to the applications desired with low vibration, high speed and high precision.

## 4. Specifications

### Electrical Specifications (T<sub>j</sub> = 25°C)

Parameters	M415B
Supply voltage	+15 to 40 VDC
Typical Supply voltage	+24—+36 VDC
Output current (Peak)	0.21 to 1.5 A
Microstep Resolutions	1, 2, 4, 8, 16, 32, 64.

### Operating Environment and Other Specifications

Cooling	Natural Cooling or forced cooling	
Operating Environment	Environment	Avoid dust, oil fog and corrosive gases
	Ambient Temperature	0°C — 50°C
	Humidity	40%RH — 90%RH
	Operating Temperature	70°C Max
	Vibration	5.9m/s <sup>2</sup> Max
Storage Temperature	-20°C — 65°C	
Weight	Approx. 150 gram (5.3 oz)	

### Mechanical specifications (unit=mm, 1 inch=25.4 mm)

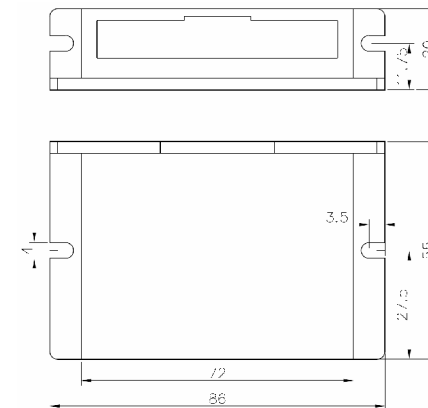

Figure 1: Mechanical dimensions

\*Recommend use side mounting for better heat dissipation

## 5. Pin Assignment and Description

The M415B has two connectors, connector P1 for control signals connections, and connector P2 for power and motor connections. The following tables are brief descriptions of the two connectors of the M415B.

### Connector P1 Configurations

Pin Function	Details
PUL	<u>Pulse signal</u> : This input represents pulse signal, effective for each rising edge; 4-5V when PUL-HIGH, 0-0.5V when PUL-LOW. For reliable response, pulse width should be longer than 1.5μs. Series connect resistors for current-limiting when +12V or +24V used.
DIR	<u>Direction signal</u> : HIGH/LOW level signal, correlative to motor rotation direction. For reliable response, DIR must be ahead of PUL by 5μs at least. 4-5V when DIR- HIGH, 0-0.5V when DIR-LOW. Motor rotation direction also depends upon the connection of the motor windings, exchange any motor phase can reverse motor rotation direction.
OPTO	Opto-coupler power supply, and the typical voltage is +5V.
ENA	<u>Enable signal</u> : This signal is used for enabling/disabling driver. High level for enabling driver and Low level for disabling driver. Usually left unconnected (enabled).

### Connector P2 Configurations

Pin Function	Details
Gnd	DC power ground
+V	DC power supply, 18~40VDC, Including voltage fluctuation and EMF voltage.
A+, A-	Motor Phase A
B+, B-	Motor Phase B

## 6. Selecting Microstep Resolution and Driver Output Current

This driver uses a 6-bit DIP switch to set microstep resolution, and motor operating current, as shown below:



## Microstep Resolution Selection

Microstep resolution is set by SW4, SW 5, SW 6 of the DIP switch as shown in the following table:

Microstep	Steps/rev.(for 1.8°motor)	SW4/MS0	SW5/MS1	SW6/MS2
1	200	ON	ON	ON
2	400	OFF	ON	ON
4	800	ON	OFF	ON
8	1600	OFF	OFF	ON
16	3200	ON	ON	OFF
32	6400	OFF	ON	OFF
64	12800	ON	OFF	OFF

### Current Settings

The first three bits (SW1, 2, 3) of the DIP switch are used to set the dynamic current. Select a setting closest to your motor's required current.

#### Dynamic current setting

Peak current (A)	SW1	SW2	SW3
0.21A	OFF	ON	ON
0.42A	ON	OFF	ON
0.63A	OFF	OFF	ON
0.84A	ON	ON	OFF
1.05A	OFF	ON	OFF
1.26A	ON	OFF	OFF
1.50A	OFF	OFF	OFF

**Notes:** Due to motor inductance, the actual current in the coil may be smaller than the dynamic current setting, particularly under high speed condition.

#### Standstill current

The standstill current of the M415B will automatically be reduced to 60% of the selected dynamic current setting one second after the last pulse. Theoretically, this will reduce motor heating to 36% (due to  $P=I^2 \cdot R$ ) of the original value. If the application needs a different standstill current, please contact Leadshine.

## 7. Typical Connections

A complete stepping system should include stepping motor, stepping driver, power supply and controller (pulse generator). The following figures are two typical connections of the M415B.

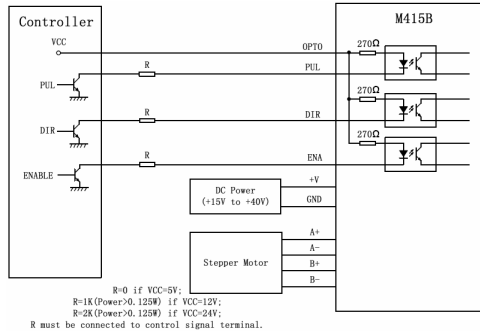

Figure 2: Typical connection with open-collector controller

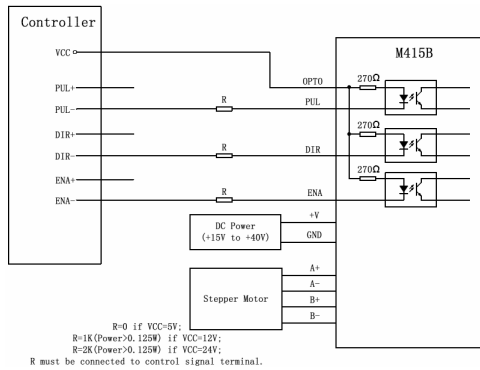

Figure 3: Typical connection with difference controller