

User Manual

EM422S

Digital Microstep Drive

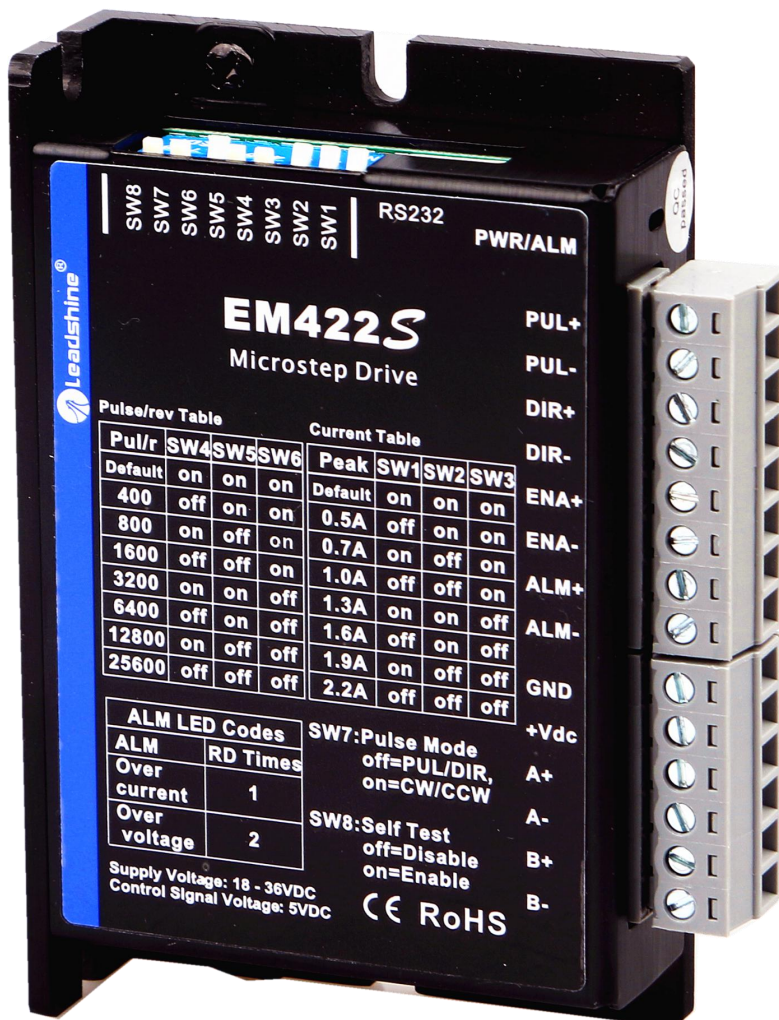

Revision 2.0
©2019 Leadshine Technology Co., Ltd.

Address: 15-20/F, Block B, Nanshan I Valley, No.3185, Shahe West Road, Nanshan District,
 Shenzhen, Guangdong, 518055, China

Tel: (86)755-26409254

Fax: (86)755-26402718

Web: www.leadshine.com

Sales: sales@leadshine.com

Support: tech@leadshine.com

Important Notice

Read this manual carefully before any assembling and using. Incorrect handling of products in this manual can result in injury and damage to persons and machinery. Strictly adhere to the technical information regarding installation requirements.

This manual is not for use or disclosure outside of Leadshine except under permission. All rights are reserved. No part of this manual shall be reproduced, stored in retrieval form, or transmitted by any means, electronic, mechanical, photocopying, recording, or otherwise without approval from Leadshine. While every precaution has been taken in the preparation of the book, Leadshine assumes no responsibility for errors or omissions. Neither is any liability assumed for damages resulting from the use of the information contained herein.

This document is proprietary information of Leadshine that is furnished for customer use ONLY. Information in this document is subject to change without notice and does not represent a commitment on the part of Leadshine. Therefore, information contained in this manual may be updated from time-to-time due to product improvements, etc., and may not conform in every respect to former issues.

Record of Revisions

Revision	Date	Description of Release
1.0	Oct, 2017	Initial Release
2.0	Jan, 2019	Modify connector, control signal circuit, delete motor cable error, etc.

Table of Contents

1.Introduction.....	1
1.1 Features.....	1
1.2 Applications.....	1
2.Specifications.....	2
2.1 Electrical Specifications.....	2
2.2 Environment.....	2
2.3 Mechanical Specifications.....	2
2.4 Elimination of Heat.....	3
3. Connection Pin Assignments and LED Indication.....	3
3.1 P1 - Control Connector Configurations.....	3
3.2 P2 - Fault Output Connector.....	4
3.3 P3 - Power Connector.....	4
3.4 P4 - Motor Connector.....	4
3.5 P5 - Tuning Port.....	4
3.6 Status LED Lights.....	4
4. Control Signal and Fault Output.....	5
4.1 Control Signal Connection.....	5
4.2 Fault output connection.....	5
5. Stepper Motor Connections.....	5
5.1 4-lead Motor Connection(recommended).....	5
5.2 6-lead Motor Connection.....	6
5.3 8-lead Motor Connection.....	6
6.Power Supply Selection.....	7
6.1 Regulated or Unregulated Power Supply.....	7
6.2 Power Supply Sharing.....	7
6.3 Selecting Supply Voltage.....	7
7.DIP Switch Configurations.....	7
7.1 Output Current Configuration (SW1-3).....	7
7.2 Micro Step Configuration (SW4-6).....	8
7.3 Pulse Mode Configuration (SW7).....	8
7.4 Self-Test Configuration (SW8).....	8
8. Wiring Notes.....	9
9. Typical Connection.....	9
10. Sequence Chart of Control Signals.....	9
11. Protection Functions.....	10
12. Troubleshooting.....	11
13. Warranty.....	12

1. Introduction

The EM422S is a new digital stepper drive based on Leadshine's widely implemented DM stepper drives (10+ millions of units in field). While retaining features of simple design, easy setup, high precision and reliability, Leadshine has also upgraded it by adopting the latest stepper control technology and added additional advanced features for better performance (10-25%), alarm output, control command smoothing, easy self-test, etc.

The EM422S is able to power 2 phase (1.8°) and 4 phase (0.9°) stepper motors smoothly with very low motor heating & noise. It can take 18-36VDC supply voltage and output 0.3 to 2.2A current. Micro step, output current, control type (step & direction or CW/CCW) and self-test can be easily done via built in DIP switches. It is an ideal choice for many applications requiring simple step & direction or CW/CCW control of NEMA 8, 11, 14 and 17 stepper motors.

1.1 Features

- Step & direction (PUL/DIR) or CW/CCW (double pulse) control
- 18-36VDC supply voltage
- 70 KHz max pulse input frequency
- 8 micro step settings of 200-25,600 via DIP switches, or 200-51,200 via software (increase by 200)
- 8 output current settings of 0.3 – 2.2A via DIP Switches, or via software (increase by 0.1)
- Configurable control command smoothing for reducing motor vibration
- Automatic idle current reduction to 50%
- Convenient self-test for easy diagnosis
- Automatic self-configuration to match wide-range NEMA 8, 11, 14 and 17 stepper motors
- Anti-Resonance for optimal torque, extra smooth motion, low motor heating and noise
- Soft-start with no “jump” when powered on
- Optically isolated inputs
- Fault output
- Over-voltage and over-current protections
- CE certified and RoHS compliant

1.2 Applications

The EM422S stepper drive is designed to power 2 phase (1.8°) or 4-phase (0.9°) NEMA 8, 11, 14 and 17 hybrid stepper motors or Permanent magnetic stepper motor (7.5° or 15°) . It can be adopted in many industries (CNC machinery, electronics, medical, automation, packaging...) for applications such as 3D printer, automation machines, medical machines, laser cutters, X-Y tables, labeling machines, pick-place devices, etc. Its excellent performance, simple design, and easy setup features make EM422S ideal for many step & direction control type applications.

2. Specifications

2.1 Electrical Specifications

Parameters	Min	Typical	Max	Unit
Output Current	0.3	-	2.2 (1.6 RMS)	A
Supply Voltage	18	24	36	VDC
Logic signal current	7	10	16	mA
Pulse input frequency	0	-	70	kHz
Minimal pulse width	72	-	-	μs
Minimal direction setup	150	-	-	μs
Isolation resistance	500	-	-	MΩ

2.2 Environment

Cooling	Natural Cooling or Forced cooling	
Operating Environment	Environment	Avoid dust, oil fog and corrosive gases
	Ambient Temperature	0 — 65°C (32 - 149°F)
	Humidity	40 — 90%RH
	Operating Temperature	0 — 50°C (32 - 122°F)
	Vibration	10-50Hz / 0.15mm
Storage Temperature	-20°C — 65°C (-4°F - 149°F)	
Weight	Approx. 150g (5.3 oz)	

2.3 Mechanical Specifications

(unit: mm [1inch=25.4mm])

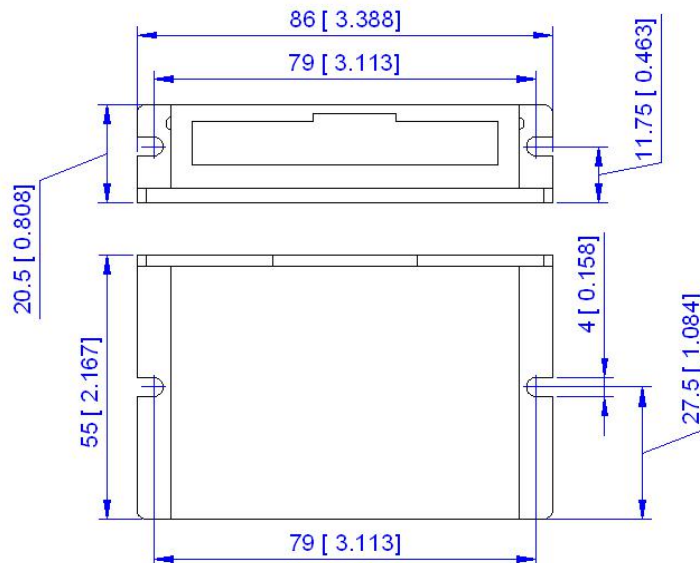

Figure 1 Mechanical specifications

* Side mounting recommended for better heat dissipation

2.4 Elimination of Heat

- EM422S's working temperature is less than 60°C (140°F)
- It is recommended to mount the drive vertically to maximize heat sink area. Use forced cooling method to cool if necessary.

3. Connection Pin Assignments and LED Indication

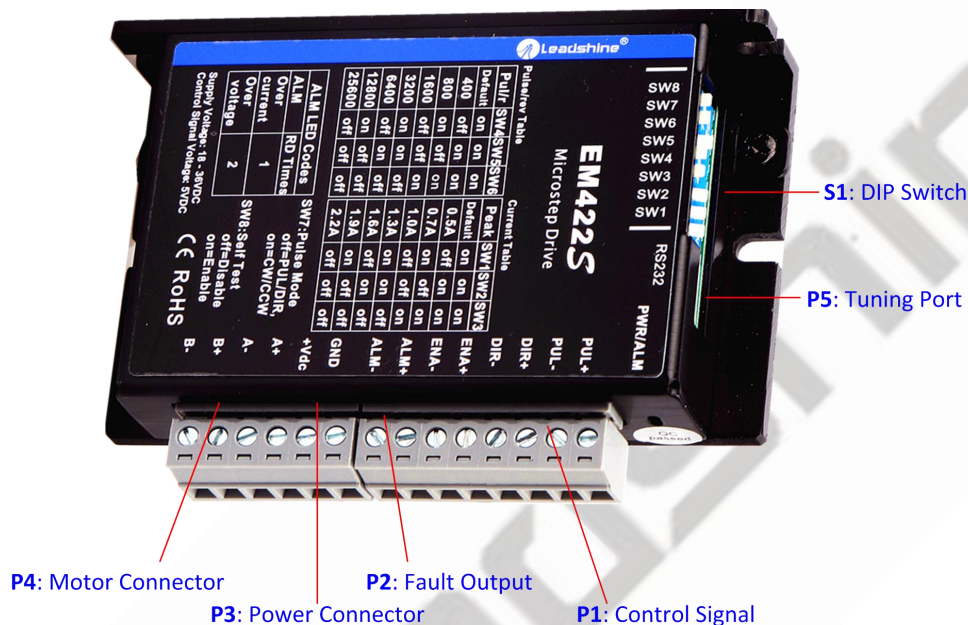

Figure 2 Connectors, DIP switches, and LED locations

The EM422S has 5 terminal block connectors P1, P2, P3, P4 and P5, 1 DIP switch selectors S1. P1 is for control signal connections, P2 is for fault output, P3 is for power connection, P4 is for motor connection and P5 is for fine tuning.

3.1 P1 - Control Connector Configurations

PIN	Details
PUL+ (CW+)	Pulse and Direction Connection: (1) Optically isolated, high level 4.5-5V, low voltage 0-0.5V. (2) Maximum 70 KHz input frequency. (3) Pulse width of 72μs or longer. (4) Single pulse (step & direction) control mode or double pulse (CW/CCW) control mode is set by DIP Switch SW7.
PUL- (CW-)	
DIR+ (CCW+)	DIR signal requires advance PUL signal minimum 150 μs in single pulse mode. (6) When the control voltage is 24V, 2K resistors are required.
DIR- (CCW-)	
ENA+	Enable Connection: Optional. (1) Optically isolated, differential. (2) Disable the drive by 4.5-5.0V input connection; enable the drive by 0-0.5 VDC connection(default no connection). (3) ENA signal requires advance DIR signal minimum 150μs in single pulse mode. (4) When the control voltage is 24V, a 2K resistor is required. (5) Enable time to be at least 200ms
ENA-	



Notes: (1) shield cables are required for P1; (2) don't tie P1&P2 cables and P3&P4 cables together.

3.2 P2 - Fault Output Connector

Pin	Details
ALM+	<u>Fault Output Connection:</u> Optional. (1) Maximum 24V/80mA output when over-voltage and over-current error protections activated. (2) Sinking or sourcing. (3) The resistance between ALM+ and ALM- is low impedance as default, and will change to high when the drive goes into error protection.
ALM-	

3.3 P3 - Power Connector

Pin	Details
GND	Connect to power supply ground connection.
+VDC	Connect to power supply positive connection. Suggest 18-36VDC power supply voltage



Warning: Don't plug/unplug P3 or P4 connector to avoid drive damage or injury while powered on.

3.4 P4 - Motor Connector

PIN	Details
A+	Connect to motor A+ wire
A-	Connect to motor A- wire
B+	Connect to motor B+ wire
B-	Connect to motor B- wire

3.5 P5 - Tuning Port

EM422S has a tuning port with RS232 to modify the drive parameters, it's only for tuning, not for equipment control because neither precision nor stability is sufficient. If you need a field bus drive, use a Leadshine RS485 or EtherCAT type drives:

(<http://www.leadshine.com/ProductSubType.aspx?type=products&category=stepper-products&producttype=stepper-drives&subtype=network-stepper-drives>)

The interface definition is as follows:

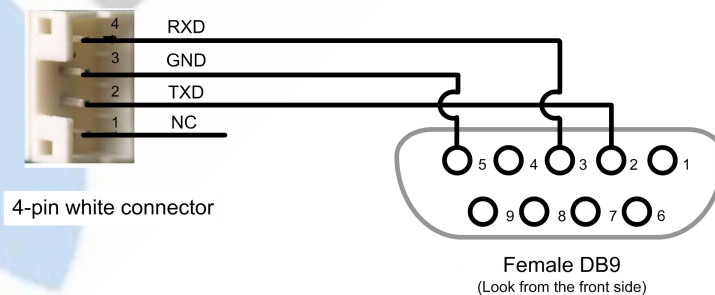

3.6 Status LED Lights

There are two LED lights for EM422S. The GREEN one is the power indicator which should be always on in normal circumstance. The RED one is a drive status indication light, which will be OFF while working normally but ON and flash 1 or 2 times in a 3-second period in the case of enabled over-current or over-voltage protection.

4. Control Signal and Fault Output

4.1 Control Signal Connection

The EM422S can accept differential or single-ended control signals (pulse, direction, and enable) in open-collector or PNP connection through the P1 connector (figure 2). It is recommended to add an EMI line filter between the power supply and the drive to increase noise immunity for the drive in interference environments.

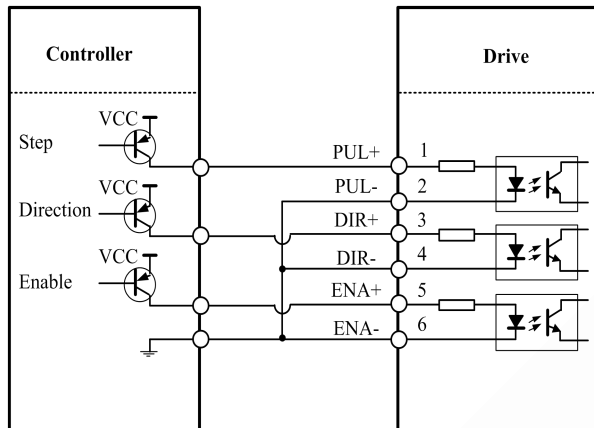

Figure 3 Connections to open-collector signals (Common-anode)

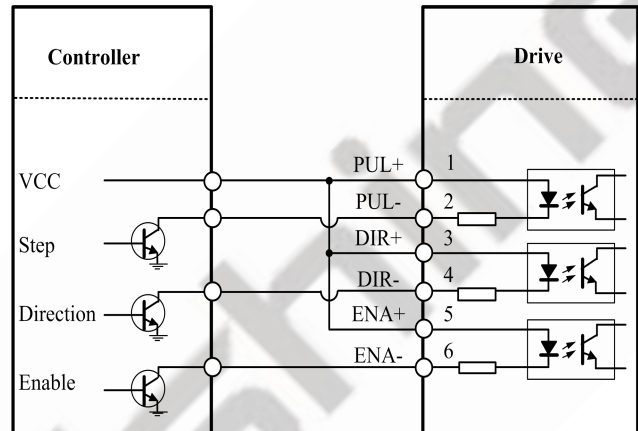

Figure 4 Connections to PNP signals (Common-cathode)

4.2 Fault output connection

When over voltage or over current protection happens, EM422S red status LED light will blink and the impedance state between ALM+ and ALM- will change (from low to high or high to low depending on configuration) and can thus be detected. Fault output connection is optional, and it can be connected either in sinking or sourcing.

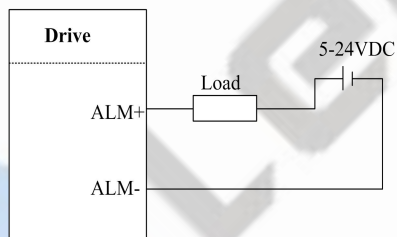

Figure 5 Sinking output

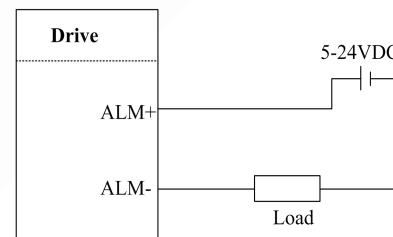

Figure 6 Sourcing output

5. Stepper Motor Connections

EM422S can drive 2-phase and 4-phase bipolar hybrid stepper motors with 4, 6, or 8 wires, Leadshine also offers easy-to-use and good-performance motors with 4-lead that have been tested with EM422S:

<http://www.leadshine.com/series.aspx?type=products&category=stepper-products&producttype=stepper-motors&subtype=hybrid-stepper-motors&series=cm>

5.1 4-lead Motor Connection(recommended)

4-lead motor is easy to use with excellent performance. Refer to figure 7 for how to connect a 4-lead stepper motor.

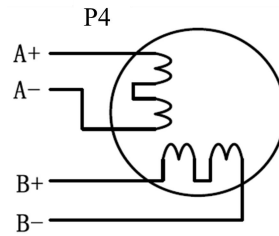
Figure 7 4-lead Motor Connection

5.2 6-lead Motor Connection

EM422S can power 6-lead stepper motors through half coil connection (half chopper) or full coil (full copper) connection. The half coil connection only uses one half of the motor's winding and is usually selected in applications requiring high speed but lower torque. The full coil connection uses the full coil winding and is usually selected in high-torque required applications. Refer to figure 8 and 9 for those two connections.

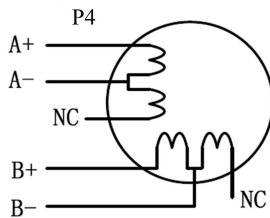
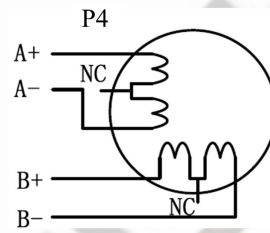
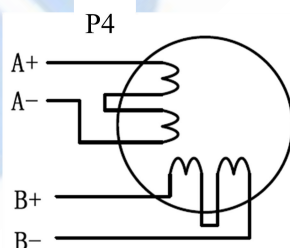
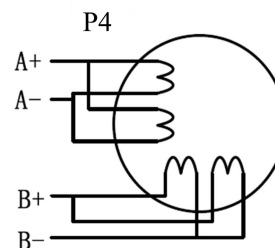

Figure 8 6-lead motor half coil connection

Figure 9 6-lead motor full coil connection

5.3 8-lead Motor Connection

EM422S can power 8-lead in series or parallel connection in series or parallel.

Series connected 8-lead stepper motors are typically implemented in applications which higher torque at lower speed movement is required. Because a stepper motors under series connection has the most inductance, the performance will start to degrade when the motor runs at higher speed. For this connection, it is suggested to set an EM422S's output RMS current to no more than 70% of the stepper motor's phase current to prevent overheating. See the figure 10 for how to connect an 8-lead stepper motor for series connection.

Parallel connected 8-lead stepper motors are typically implemented in applications which higher torque at high speed movement is required. Compared with series connection, a parallel connected stepper motor has lower inductance and therefore have better torque performance at higher speed movement. Although setting the drive output current to 1.4 times of driven motor phase current will get the most torque, it is suggested to set an EM422S's output current (peak of sinusoidal) to no more than 1.2 times the stepper motor's phase current to prevent overheating. Refer to the figure 11 for how to connect an 8-lead stepper motor for parallel connection.

Figure 10 8-lead motor series connection

Figure 11 8-lead motor parallel connection

6. Power Supply Selection

EM422S is designed to power small size stepping motors (frame sizes NEMA 8 to 17) made by Leadshine or other motor manufacturers. To get optimal performances, it is important to select proper power supply type, voltage, and supply output current. In general power supply voltage determines the high speed performance of a stepper motor, while drive output current determines the driven motor torque output. Higher supply voltage can increase motor speed torque performance, but at the same time result in more noise and motor heating. For low motor speed applications, it is suggested to use lower supply voltage power supplies.

6.1 Regulated or Unregulated Power Supply

Both regulated and unregulated power supplies can be used to power an EM422S. Theoretically unregulated power supplies are preferred due to their ability to withstand back EMF current surge and faster response for current change. If you prefer to use a regulated power supply instead, it is suggested to choose one specially designed for stepper or servo controls such as one Leadshine RPS series power supply:

<http://www.leadshine.com/ProductSubType.aspx?type=products&category=other-products&producttype=power-supplies&subtype=regulated-switching-power-supplies>. In the case when only general purpose switching power supplies are available, choose one with “OVERSIZED” current output rating (for example, using a 4A power supply for 3A stepper motor) to avoid current clamp. On the other hand, if unregulated supply is used, one may use a power supply of lower current rating than that of motor (typically 50% - 70% of motor phase current). The reason is that the drive only draws current from an unregulated power supply during the ON duration of the PWM cycle, but not during the OFF duration.

6.2 Power Supply Sharing

Multiple EM422S drives can share the same power supply, if that power supply has enough capacity. To avoid cross interference, connect each EM422S DIRECTLY to that shared power supply separately instead of connecting those power connectors of drives in daisy-chain connection.

6.3 Selecting Supply Voltage

EM422S's operating voltage is 18–36 VDC. Because of voltage increasing from potential power line voltage fluctuation and back EMF voltage generated during motor deceleration, it is suggested to use a 24 VDC power supply.

7. DIP Switch Configurations

The EM422S has 8-bit DIP Switch to configure output current, microstep resolution, pulse mode and self-test as shown below, the factory setting of SW1-SW8 is **ON, ON, ON, OFF, OFF, ON, OFF, OFF**. Default means that parameters can be modified by Leadshine ProTuner software.

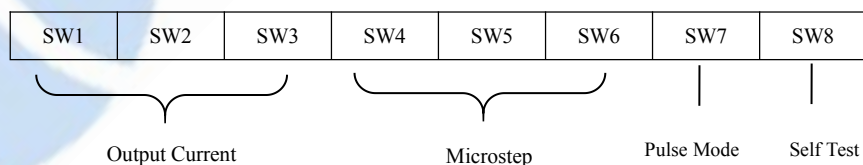

7.1 Output Current Configuration (SW1-3)

The EM422S has 8 output current settings which can be configured through DIP switch SW1, SW2 and SW3.

For a given stepper motor, as normal setting the output current to 1.4 times of motor phase current, will make it output larger torque, but at the same time cause more heating for both the motor and drive. Therefore, it is suggested to set a output current (peak of sinusoidal) to no more than 1.2 times the stepper motor's (for 4-lead motor) phase current to prevent overheating .

The SW1, SW2 and SW3 are used to set the dynamic current. Select a setting closest to your motor's required current. When they are set to **ON, ON, ON**, the output current can be set by Leadshine ProTuner.

Peak Current	RMS Current	SW1	SW2	SW3
0.3A	0.21A (default)	ON	ON	ON
0.5A	0.35A	OFF	ON	ON
0.7A	0.49A	ON	OFF	ON
1.0A	0.71A	OFF	OFF	ON
1.3A	0.92A	ON	ON	OFF
1.6A	1.13A	OFF	ON	OFF
1.9A	1.34A	ON	OFF	OFF
2.2A	1.56A	OFF	OFF	OFF

7.2 Micro Step Configuration (SW4-6)

Each EM422S has 8 micro step settings which can be configured through DIP switch SW4, SW5, SW6. See the following table for detail. When they are set to **ON, ON, ON**, the microstep can be set via Leadshine ProTuner.

Micro step	Pulses/Rev. (for 1.8°motor)	SW4	SW5	SW6
1	200 (default)	ON	ON	ON
2	400	OFF	ON	ON
4	800	ON	OFF	ON
8	1600	OFF	OFF	ON
16	3200	ON	ON	OFF
32	6400	OFF	ON	OFF
64	12800	ON	OFF	OFF
128	25600	OFF	OFF	OFF

7.3 Pulse Mode Configuration (SW7)

DIP switch SW7 is used to configure the control mode. Factory setting is single pulse (step & direction, or pulse & direction) control. Setting to ON to change the control model to double pulse (CW/CCW) control type.

7.4 Self-Test Configuration (SW8)

For test and system diagnosis purpose, EM442S is featured with Self-Test. Anytime DIP switch SW8 is switched to ON position, the drive will automatically rotate the driven stepper motor back and forth for one round in each direction. Set this switch position to OFF for normal operation.

8. Wiring Notes

- In order to improve anti-interference performance of the drive, it is recommended to use twisted pair shield cable.
- To prevent noise incurred in PUL/DIR signal, pulse/direction signal wires and motor wires should not be tied up together. It is better to separate them by at least 10 cm; otherwise the disturbing signals generated by motor will easily disturb pulse direction signals, causing motor position error, system instability and other failures.
- If only one power supply serves multiple EM422S drives, separately connecting the drives to the power supply is recommended instead of daisy-chaining.
- It is prohibited to pull and plug connector P3&P4 while the drive is powered ON, because there is high current flowing through motor coils (even when motor is at standstill), which will cause extremely high back-EMF voltage surge, which may damage the drive.

9. Typical Connection

A complete stepping system should include stepping motor, stepping drive, power supply and controller (pulse generator). A typical connection is shown as figure 12.

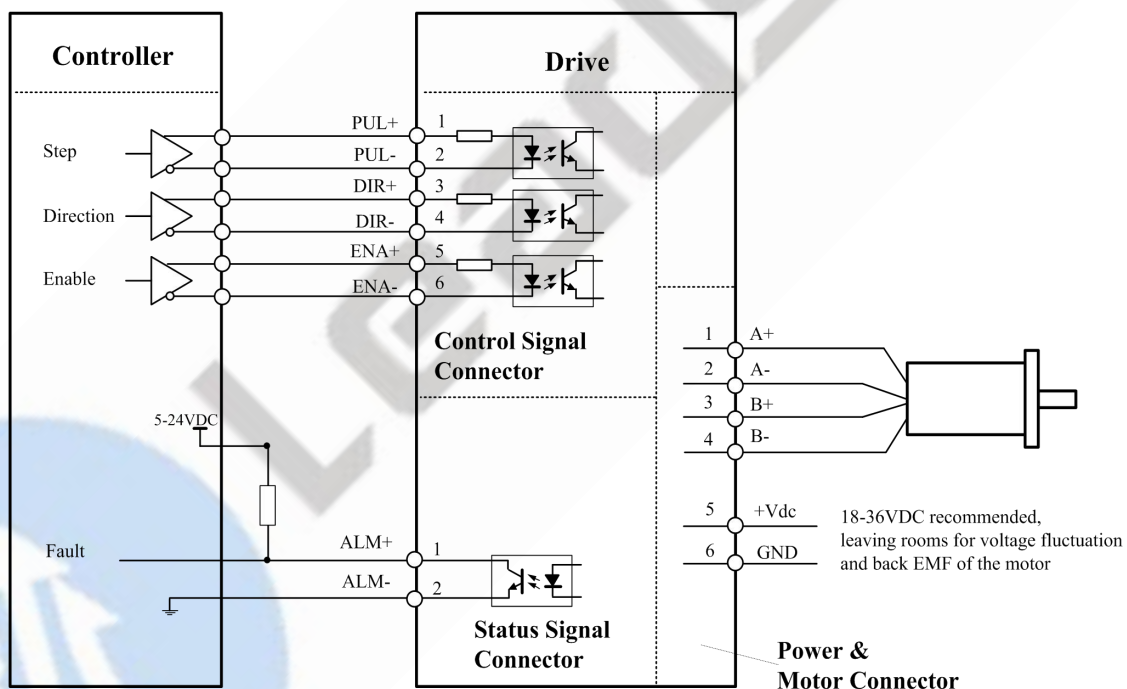

Figure 12 Typical connection

10. Sequence Chart of Control Signals

In order to avoid some fault operations and deviations, PUL, DIR and ENA should abide by some rules, shown as following diagram:

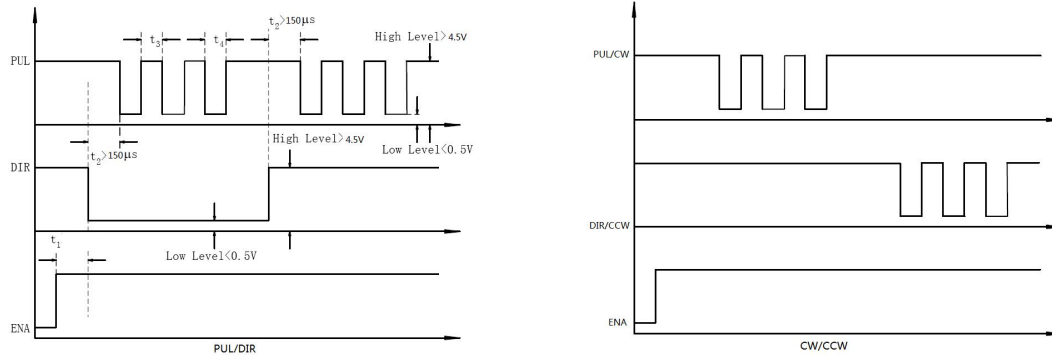

Figure 13 Sequence chart of control signals

Remark:

- t_1 : ENA must be ahead of DIR by at least 500ms. Usually, ENA+ and ENA- are NC (not connected). See “Connector P1 Configurations” for more information
- t_2 : DIR must be ahead of PUL effective edge by 150 μ s to ensure correct direction
- t_3 : Pulse width not less than 72 μ s, duty cycle recommend 50%
- t_4 : Low level width not less than 72 μ s
- For control signals, both PUL,DIR and ENA are activated by rising edges in default

11. Protection Functions

EM422S incorporates are built with over-voltage and over-current error protections. When it is under error protection, the red LED light will blink for 1 or 2 or 4 times in a period of 3 seconds. If fault output connection is connected, the impedance mode between ALM+ and ALM- will be changed (See “Fault Output Configuration” section for detail).



Priority	Time(s) of Blink	Sequence wave of red LED	Description
1 st	Always on		The drive was short-circuited or burned out.
1 st	1		Over-current protection activated when peak current exceeds the limit.
2 nd	2		Over-voltage protection activated when drive working voltage is greater than 42VDC

Figure 14 Error Protections

When over-current and over-voltage protections are activated, the motor shaft will be free or the red LED blinks. Reset the drive by restart it to make it function properly after removing above problems.

12. Troubleshooting

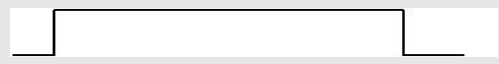
In the event that your drive doesn't operate properly, the first step is to identify whether the problem is electrical or mechanical in nature. The next step is to isolate the system component that is causing the problem. As part of this process you may have to disconnect the individual components that make up your system and verify that they operate independently. It is important to document each step in the troubleshooting process. You may need this documentation to refer back to at a later date, and these details will greatly assist our Technical Support staff in determining the problem should you need assistance.

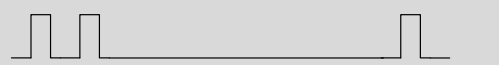
Many of the problems that affect motion control systems can be traced to electrical noise, controller software errors, or mistake in wiring.

Problem Symptoms and Possible Causes

Trouble	Solution Measures
Motor is not rotating	No power, to start power supply
	Pulse/revolution setting is wrong
	DIP switch current setting is wrong
	Fault condition exists or the drive is disabled
Motor rotates in the wrong direction	Motor phases may be connected in reverse
	Pulse mode may be wrong
Red light blinking	Red light blinks 1 time or always on, try not to connect the motor and restart the power supply
	Red light blinks 2 times, check the power voltage and restart the power supply
	Red light blink 4 times, the motor is not connected or has broken circuit.
Erratic motor motion	Current setting is too small, losing steps
	Wrong motor connection or has broken circuit in motor coil.
	The current of the control signals is not in the range of 7-15mA
	Control signals don't meet the requirements of chapter 10 , check the waveform of the control signals
Motor stalls or loss steps	Output current of the drive is too small or motor torque is not enough
	Acceleration is set too high
	Power supply voltage too low
	Modify the activated edge value in the ProTuner or the control signal is interfered with.
Excessive motor and drive heating	Inadequate heat sinking / cooling
	Automatic current reduction function not being utilized
	Reduce output current

13. Warranty

Twelve Month Warranty

Leadshine Technology Co., Ltd. warrants its products against defects in materials and workmanship for a period of 12 months from shipment out of factory. During the warranty period, Leadshine will either, at its option, repair or replace products which proved to be defective.

Exclusions

The above warranty does not extend to any product damaged by reasons of improper or inadequate handlings by customer, improper or inadequate customer wirings, unauthorized modification or misuse, or operation beyond the electrical specifications of the product and/or operation beyond environmental specifications for the product.

Obtaining Warranty Service

To obtain warranty service, please contact your seller to obtain a returned material authorization number (RMA) before returning product for service.

Shipping Failed Products

If your product fail during the warranty period, please contact your seller for how and where to ship the failed product for warranty or repair services first, you can also e-mail customer service at tech@leadshine.com to obtain a returned material authorization number (RMA) before returning product for service. Please include a written description of the problem along with contact name and address.